

NO	QTY	PART NO	DESCRIPTION	STD SEAL KIT	LIGHT SPRING KIT	HEAVY SPRING KIT
1	1	23350124	SPRING, COMPRESSION		X	X
2	1	23350126	SPRING, COMPRESSION			X
3	1	39050026	O-RING, (-018)	X		
4	2	39051079	O-RING, (6mm X 1)	X		
5	2	39051087	O-RING, (4mm X 3)	X		
6	2	39051132	O-RING, (8.75mm X 1.8)	X	X	X
7	1	39051133	O-RING, (45.5mm X 2)	X	X	X
8	1	39053056	WIPER, PRESS-IN, 22mm	X		
9	1	81000052	CONTACT BOLT, WS, 7MPa, 16 & 26kN			
10	2	81400200	PLUG, MANIFOLD, 7MPa, M6			
11	1	23350125	SPRING, COMPRESSION		X	
N/A	N/A	L6010011	KIT, SEAL, WS, 7MPa, TF, FA, 26kN	NOTED	N/A	N/A
N/A	N/A	L6110026	KIT, SPRING, WS, 7MPa, TF, FA, 26kN	N/A	NOTED	N/A
N/A	N/A	L6110027	KIT, SPRING, WS, 7MPa, TF, FA, 26kN	N/A	N/A	NOTED
N/A	N/A	ISL1015	INSTRUCTION SHEET, WS, 7MPa, TF, FA, 26kN	N/A	N/A	N/A

See Instruction Sheet ISL1015 For Service Instructions.
 Lubricate All Seals With Clean Hydraulic Oil Prior To Assembly.
 Do Not Use Silicone Base Lubricants.



PARTS LIST	 VEKTEK, INC. 1334 E. SIXTH AVE. P.O. BOX 625 EMPORIA, KS. 66801 U.S.A.
	ASSEMBLIES AFFECTED L1-0222-00H L1-0222-00L
PARTS LIST, ASSY, WS, 7MPa, TF, FA, 26kN SIZE A LPL1023	REV B SHEET 1 OF 1

B	3849	RELEASE	MJUST	7/8/19
REV	IN ACCORDANCE WITH ECN	EFFECTIVE DATE	REVISED BY	DATE
DRW BY:	N. KARRAS	DRAWING STATUS: Released		
DATE:	03/21/14	PRODUCTION APPROVED FOR RELEASED STATUS ONLY		

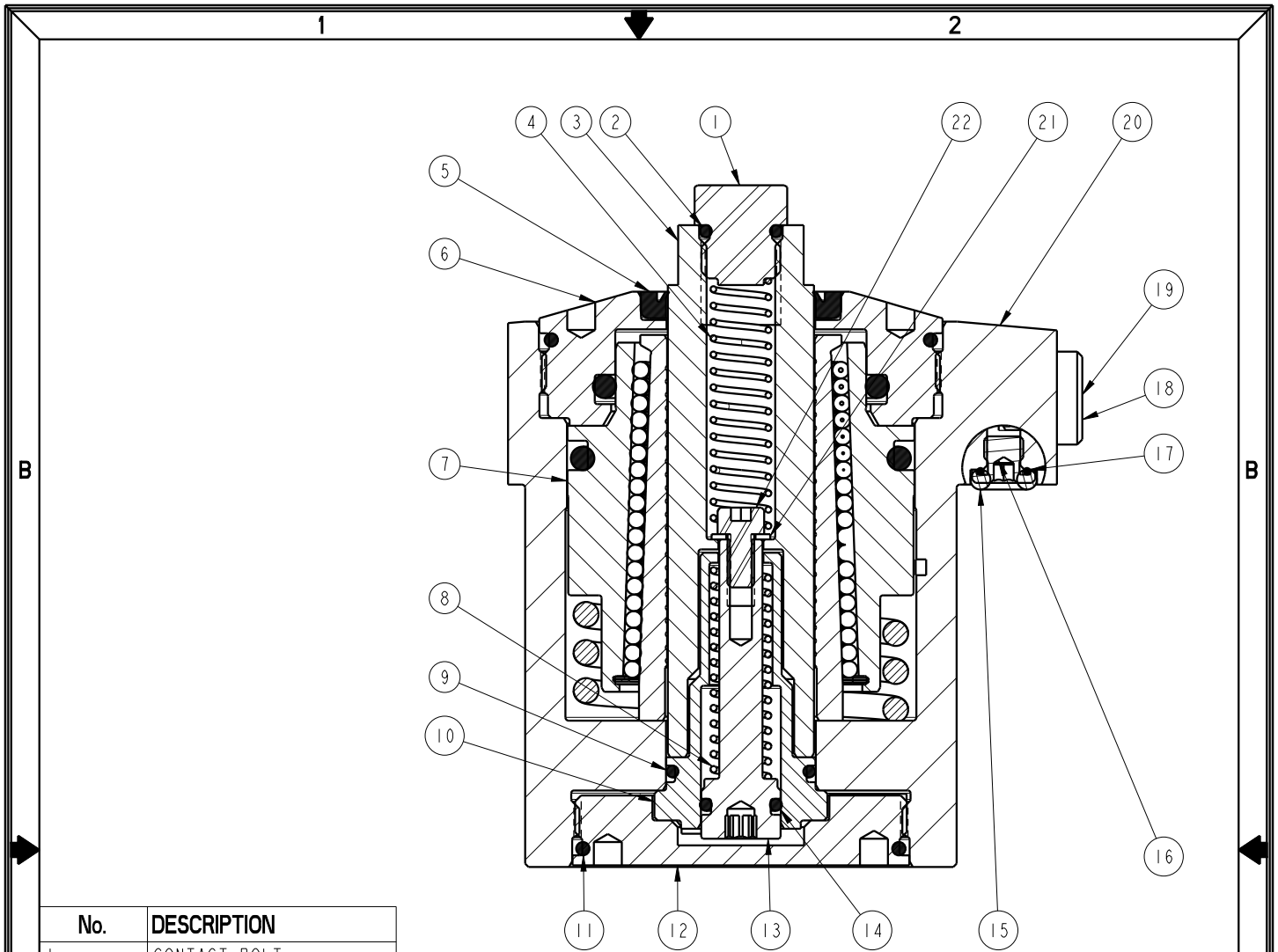

No.	DESCRIPTION
1	CONTACT BOLT
2	O-RING (8.75mm X 1.8)
3	PLUNGER
4	SPRING
5	WIPER
6	TOP CAP
7	COLLET ASSY
8	SPRING
9	O-RING (-018)
10	RETAINER
11	O-RING (45.5mm X 2)
12	BOTTOM CAP
13	PISTON
14	O-RING (8.75mm X 1.8)
15	O-RING (4mm X 3)
16	PLUG
17	O-RING (6mm X 1)
18	BREATHER
19	PLUG
20	BODY
21	WASHER
22	SHCS

TOOL LIST	
<input type="checkbox"/>	14mm & 19mm Open End Wrench
<input type="checkbox"/>	3mm & 4mm Hex Key
<input type="checkbox"/>	Vekttek #ATL10323 Spanner Wrench
<input type="checkbox"/>	12mm Dia. Or Smaller Drift Or Equivalent Rod

INSTALLATION INSTRUCTIONS

VEKTEK, INC.
1334 E. SIXTH AVE. P.O. BOX 625
EMPORIA, KS. 66801 U.S.A.

B	3141	RELEASE	NJK	11/15/16
REV	IN ACCORDANCE WITH ECN	EFFECTIVE DATE	REVISED BY	DATE
DRW BY:	N. KARRAS	DRAWING STATUS: Released		
DATE:	05/16/16	PRODUCTION APPROVED FOR RELEASED STATUS ONLY		

ASSEMBLIES AFFECTED
L1-0222-00H
L1-0222-00L

INSTRUCTION SHEET, WS, 7MPo, TF, FA, 26kN	
SIZE A	ISL1015
REV B	

Read all instructions before disassembly
Refer to the illustration on page 1 for component part numbers and tool list

Disassembly

1. Remove work support from fixture. Wipe clean to remove external contaminants.
2. With 19mm wrench at plunger (3) and 14mm wrench at contact bolt (1), unscrew contact bolt (1) from plunger (3). Remove O-ring (2) from contact bolt (1).
3. Remove contact spring (4) from inside plunger (3).
4. Clamp work support body (20) in vise with bottom side facing up.
5. Using Vektek #ATL10323 spanner wrench, unscrew bottom cap (12) from work support body (20). Remove O-ring (11) from bottom cap (12).
6. Remove work support body (20) from vise. Insert 4mm hex key into piston (13) thru the bottom of work support. Insert 3mm hex key into cap screw (22) inside plunger (3) and unscrew cap screw (22). Remove cap screw (22) and washer (21) from inside plunger (3).
NOTE: PISTON (13) IS LOOSE AND NO LONGER FASTENED TO THE ASSEMBLY.
7. Remove piston (13) and return spring (8) from inside retainer (10). Remove O-ring (14) from piston (13). CAUTION: RETURN SPRING (8) AND CONTACT SPRING (4) ARE NOT INTERCHANGEABLE, NOTE LOCATION AND KEEP SEPARATE FOR REASSEMBLY.
8. Gently slide plunger (3) out from top of work support.

Caution: Do not expose work support clamping mechanism (7) located underneath the top cap (6) to any type of cleaning solutions. Removal of top cap (6) or clamping mechanism (7) terminates product warranty.

9. Remove wiper (5) from top cap (6). Be careful not to damage wiper bore or bore below wiper (5).
10. From top of work support place drift or equivalent rod on top of retainer (10) and push downward until retainer (10) comes free from body (20). Remove O-ring (9) from retainer (10).
11. If work support hydraulics are manifold fed from fixture, remove O-ring (15) from manifold port of work support (20) mounting flange (2 places).
12. If work support hydraulics are not manifold fed from fixture, insert 3mm hex key into plug (16) located at manifold port of work support (20) mounting flange and unscrew plug (16) (2 places). Remove O-ring (17) from plug (16).
13. Thoroughly clean contact bolt (1), contact spring (4), plunger (3), cap screw (22), washer (21), retainer (10), bottom cap (12), piston (13), plugs (16), return spring (8) and set aside to dry.
14. Wipe clean bottom cap seal bore and retainer seal bore located in bottom of body (20). Wipe clean wiper bore located in top cap (6). Wipe clean manifold ports located on body (20) mounting flange.

		
VEKTEK, INC. 1334 E. SIXTH AVE. P.O. BOX 625 EMPORIA, KS. 66801 U.S.A.		
INSTRUCTION SHEET, WS, 7MPo, TF, FA, 26kN		
SIZE A	ISL1015	REV B
<small>FORM FEG041-IS-ASIZE, REV. B</small>		

Assembly

1. Lubricate new O-rings (2), (9), (11), (14), (15), (17) and outside diameter of new wiper (5) with clean hydraulic oil (Vektek 65-0010-01 or equivalent). Also, apply light film of hydraulic oil to outside surface of plunger (3)
2. Press wiper (5) into top cap (6) taking extra care to install squarely without excess force. CAUTION: IMPROPER INSTALLATION COULD DAMAGE WIPER (5) CAUSING EXCESS WIPER DRAG.
3. Install O-ring (9) onto retainer (10).
4. Install retainer (10) into bore through bottom of body (20). For proper install depth, retainer (10) should shoulder against body (20).
5. Gently install plunger (3) into work support through wiper (5) taking care not to damage wiper (5). Plunger (3) should move freely without binding. Lightly push plunger (3) downward until bottoms.
6. Install O-ring (14) onto piston (13).
7. Slide return spring (8) onto piston (13) and insert piston (13) and return spring (8) into retainer (10) bore. Insert 4mm hex key into piston (13) and push inward to compress return spring (8). While holding piston (13) and return spring (8) in compressed position, install washer (21) onto cap screw (22) dropping thread side down through top of plunger (3). Insert 3mm hex key into cap screw (22) and torque to 4.5 N-m (40 in-lb). CAUTION: CONTACT SPRING (4) AND RETURN SPRING (8) ARE NOT INTERCHANGEABLE.
8. Install O-ring (11) onto bottom cap (12)
9. Clamp work support body (20) into vise with bottom side facing up.
10. Screw bottom cap (12) into bottom of work support body (20). Using Vektek #ATL10323 spanner wrench, torque bottom cap (12) to 120 N-m (90 ft-lb).
11. Remove work support body (20) from vise and position with plunger (3) upward. Insert contact spring (4) into hole through top of plunger (3). Contact spring (4) will pilot onto cap screw (22).
12. Install O-ring (2) onto contact bolt (1).
13. Screw contact bolt (1) into top of plunger (3). With 19mm wrench at plunger (3) and 14mm wrench at contact bolt (1) torque to 13.5 N-m (120 in-lb).
14. If work support hydraulics are manifold fed from fixture, install new O-ring (15) into manifold port of work support body (20) mounting flange (2 places).
15. If work support hydraulics are not manifold fed from fixture, install O-ring (17) onto plug (16) insert 3mm hex key into plug (16) and torque to 3 N-m (25 in-lb) (2 places).

 VEKTEK, INC. 1334 E. SIXTH AVE. P.O. BOX 625 EMPORIA, KS. 66801 U.S.A.		
INSTRUCTION SHEET, WS, TWPo, TF, FA, 26kN		
SIZE A	ISL1015	REV B
FORM FEG041-1S-ASIZE, REV. B		

SHEET 3 OF 3